

HARDWARE • HERRAJES

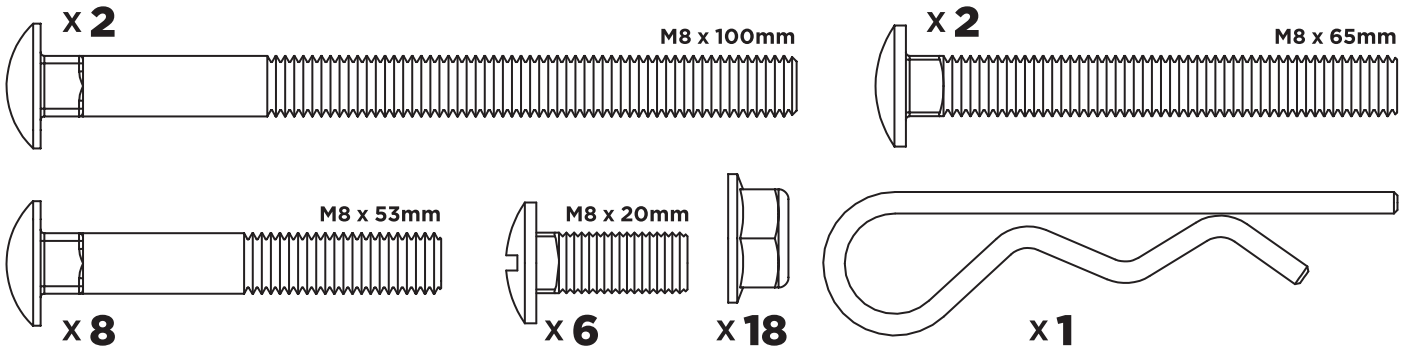

TOOLS NEEDED • HERRAMIENTAS NECESARIAS



IMPORTANT! • IMPORTANTE!

DO NOT WRENCH TIGHTEN NUTS UNTIL ASSEMBLY IS COMPLETE
NO APRIETES LAS TUERCAS CON LLAVE HASTA QUE EL ENSAMBLAJE ESTÉ COMPLETO

ASSEMBLY INSTRUCTIONS • INSTRUCCIONES DE ENSAMBLAJE





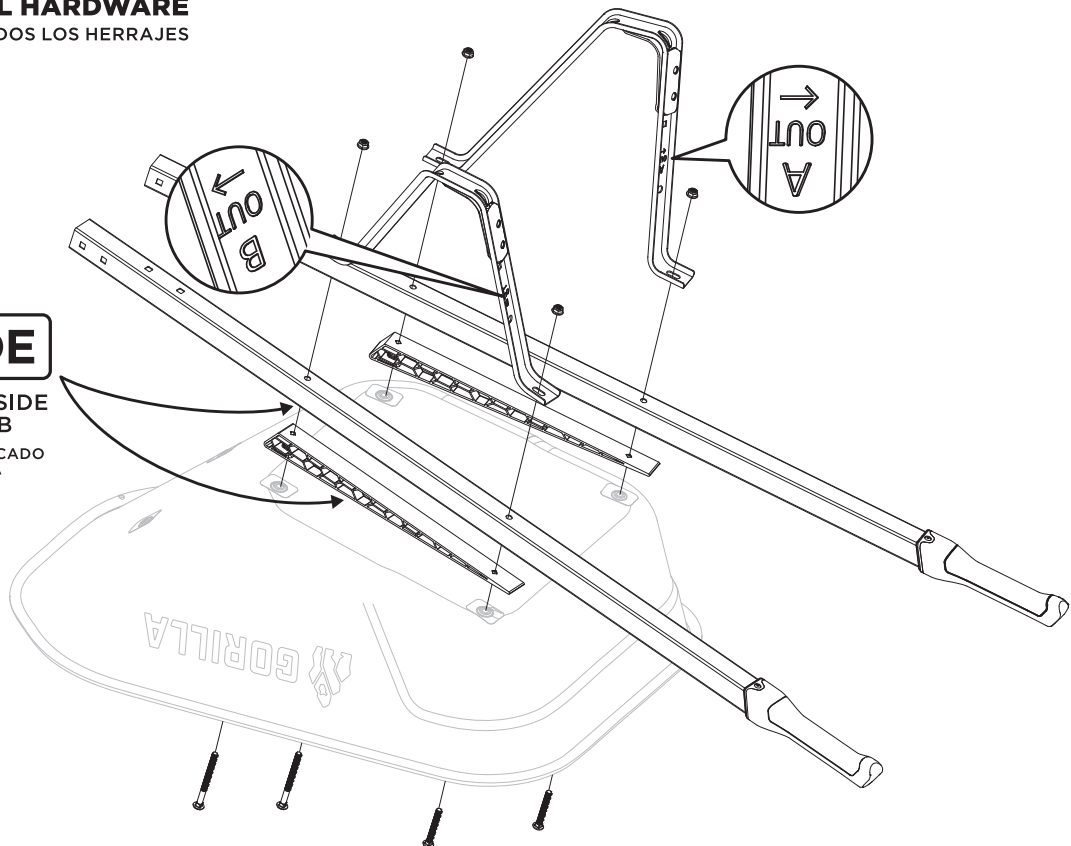

HAND-TIGHTEN ALL HARDWARE
APRIETA CON LA MANO TODOS LOS HERRAJES

TUB SIDE

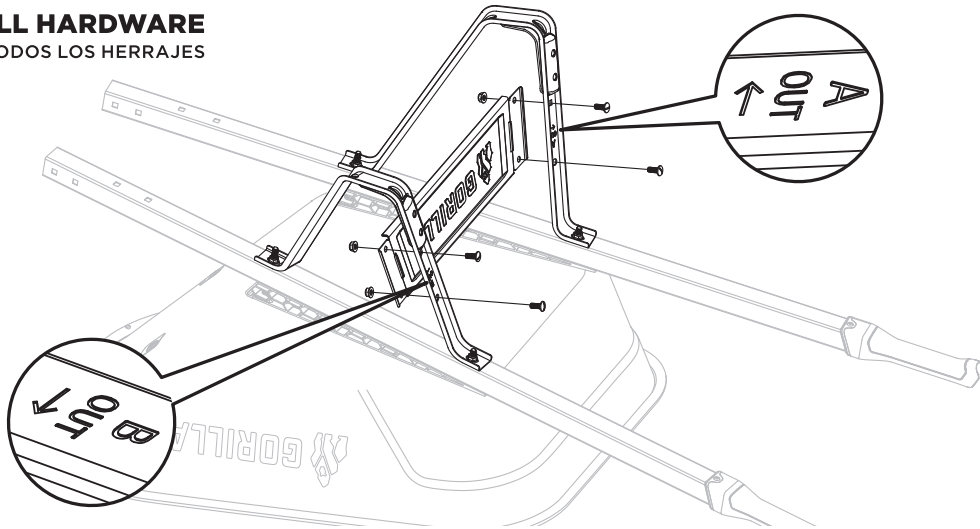
PLACE MARKED SIDE TOWARDS TUB
COLOCA EL LADO MARCADO HACIA LA BAÑERA

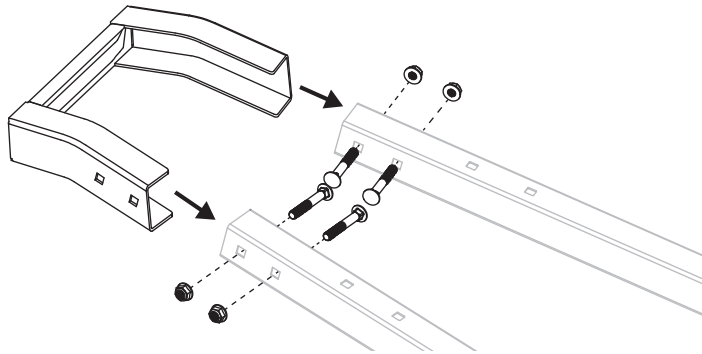
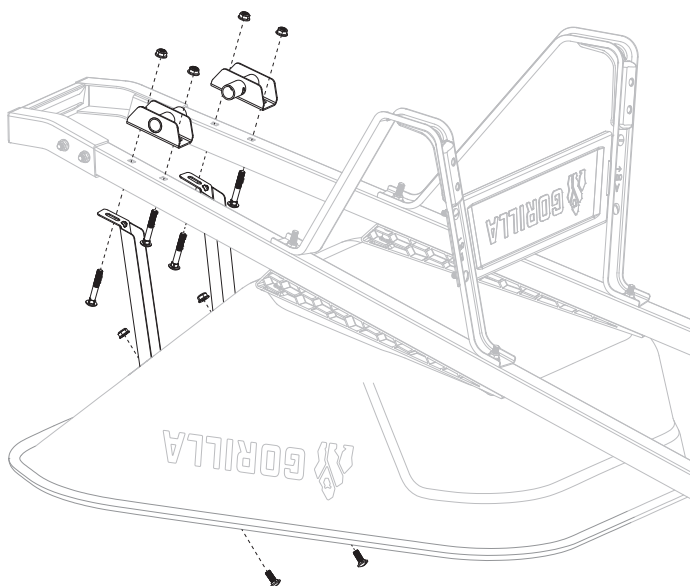

2M8 x 20mm X 4  X 4**HAND-TIGHTEN ALL HARDWARE**
APRIETA CON LA MANO TODOS LOS HERRAJES**3**M8 x 53mm X 4  X 4**HAND-TIGHTEN ALL HARDWARE**
APRIETA CON LA MANO TODOS LOS HERRAJES**4**M8 x 53mm X 4 M8 x 20mm X 2  X 6**HAND-TIGHTEN ALL HARDWARE**
APRIETA CON LA MANO TODOS LOS HERRAJES**5** X 1**WRENCH TIGHTEN ALL NUTS**
APRIETA CON LLAVE TODAS LAS TUERCAS